

Lecture 6

Molecular beam techniques

In a basic molecular beam apparatus, a stream of molecules with narrow energy distribution undergoes scattering.

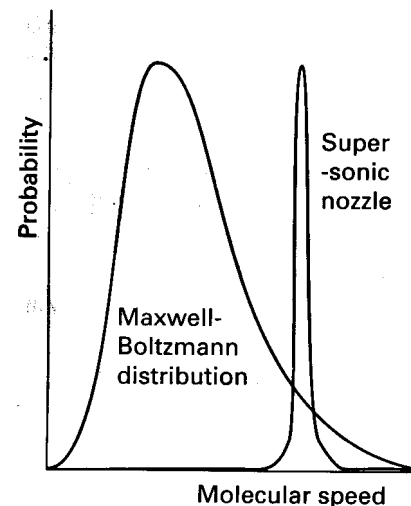

22.19 The shift in the mean speed and the width of the distribution brought about by use of a supersonic nozzle.

If the mean free path of molecules is smaller than the diameter of the pinhole, collisions happen outside the source. The effect of these collisions is to make a unidirectional flow. Within the beam, all the molecules have similar speeds and there is a unidirectional flow. The translational temperature of the molecules can be as low as 1K. These jets are called supersonic jets.

J. B. Anderson, R. P. Andres and J. B. Fenn, in *Molecular Beams*, John Ross, Ed. Adv. Chem. Phys. Vol. 10, Interscience Publishers, New York, 1966.
P. W. Atkins, *Physical Chemistry*, 6th Ed. 2000.

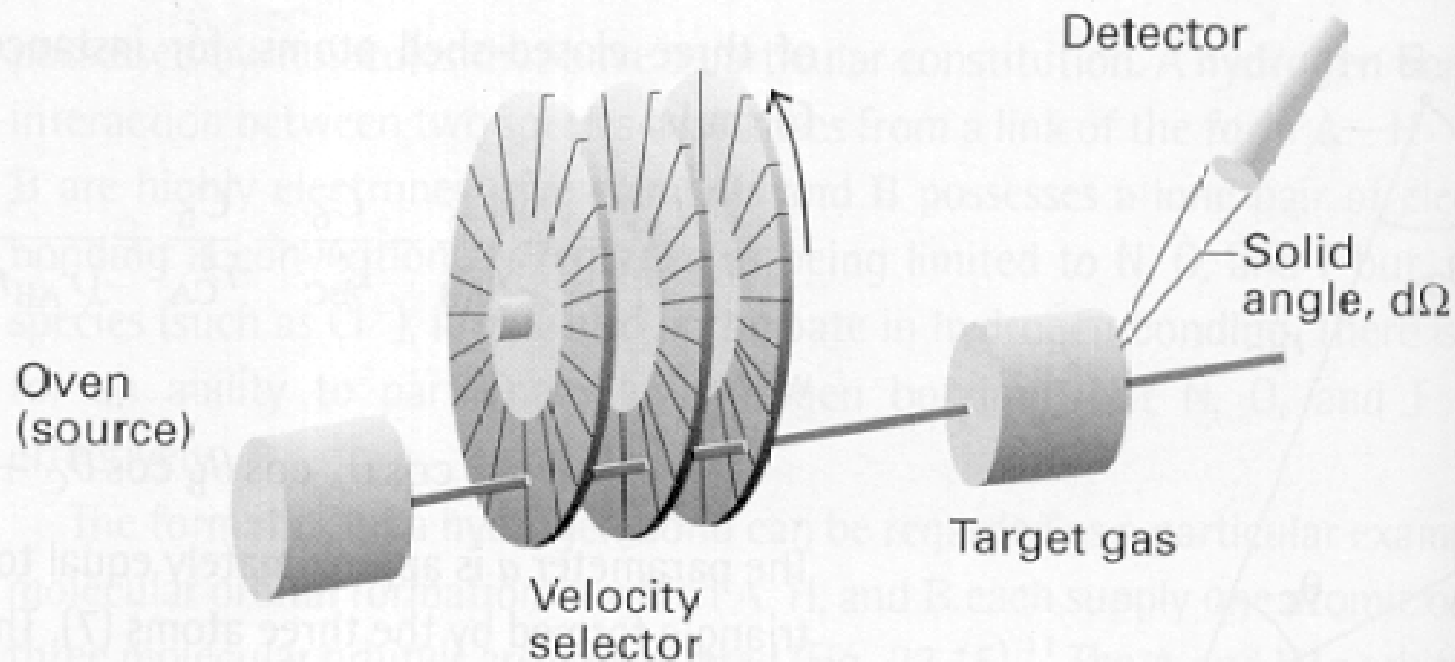

22.18 The basic arrangement of a molecular beam apparatus. The atoms or molecules emerge from a heated source, and pass through the velocity selector, a train of rotating disks. The scattering occurs from the target gas (which might take the form of another beam), and the flux of particles entering the detector set at some angle is recorded.

Beam techniques

Free jet expansion

Supersonic expansion, Mach number

Seeded beams

Pulsed beams

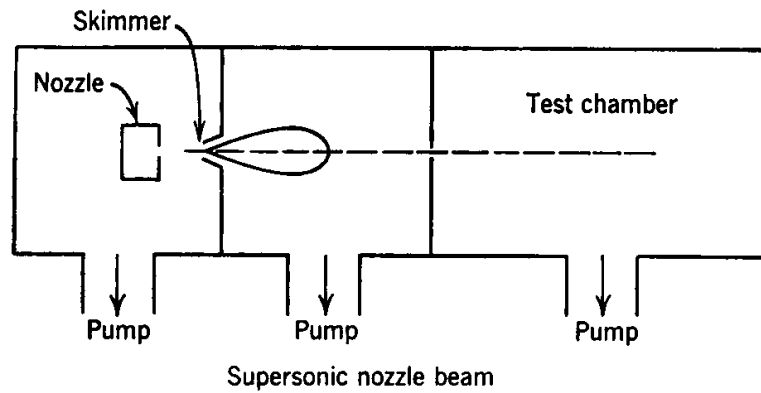
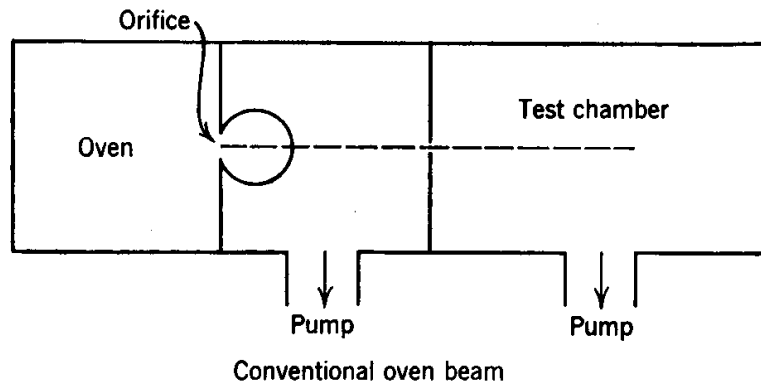
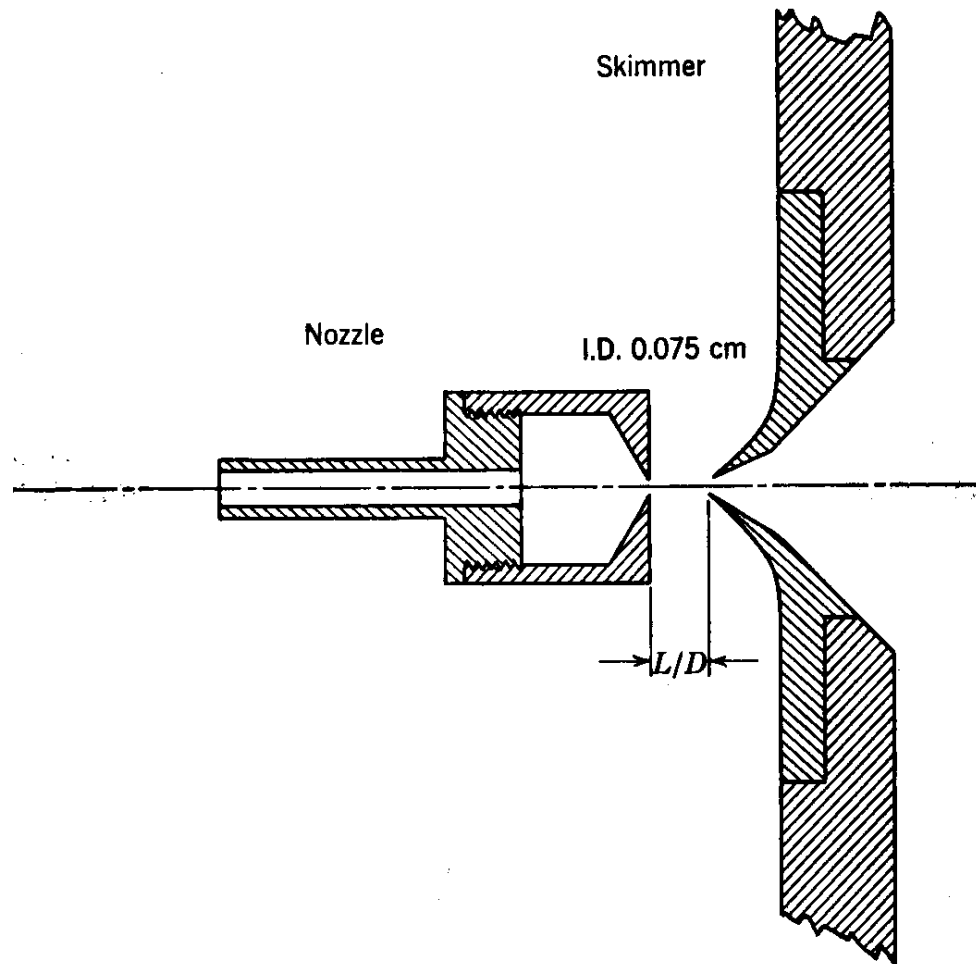
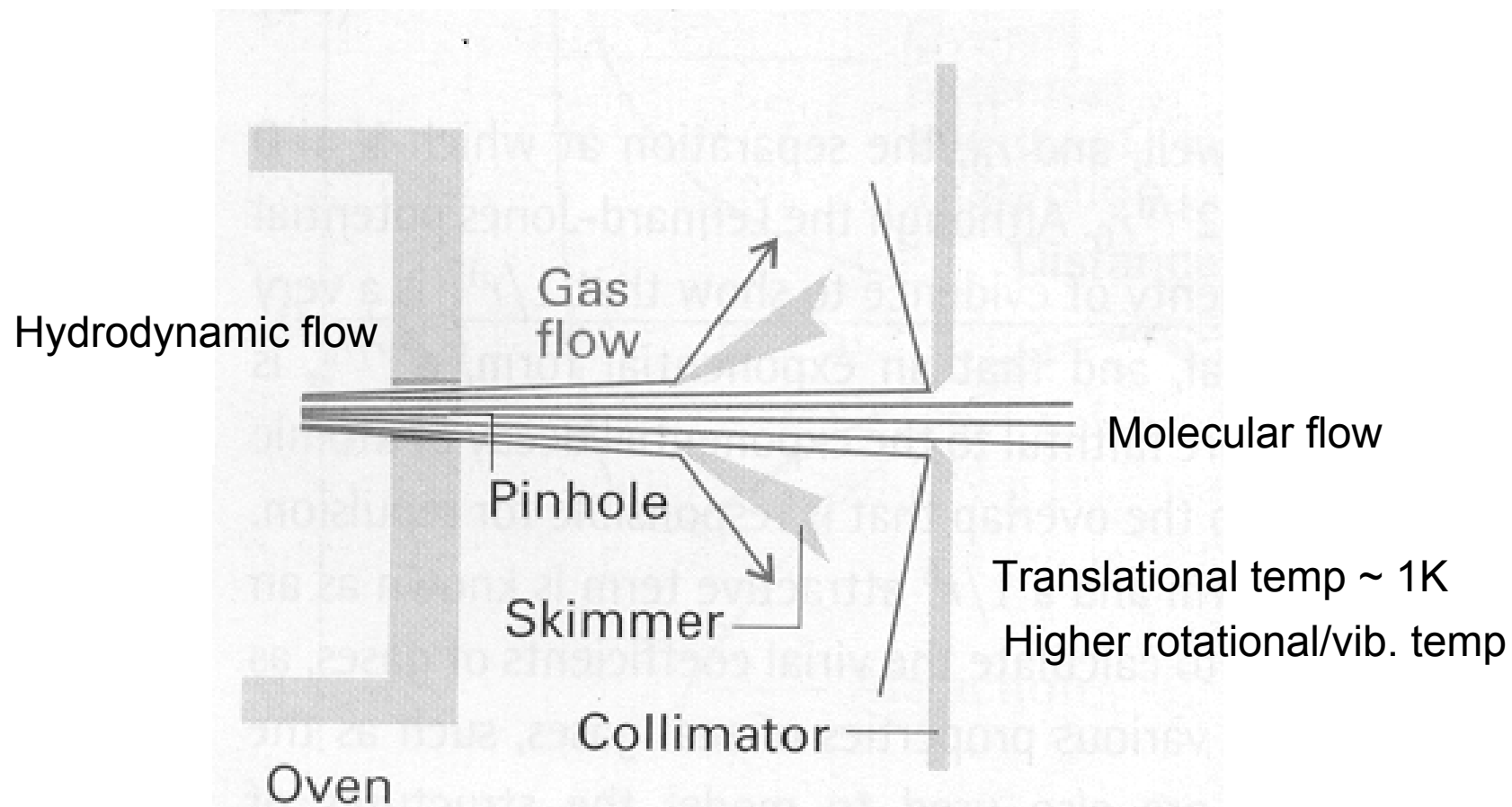

Fig. 1. Schematic representation of oven beam and nozzle beam systems. The closed curves downstream of the slit and skimmer represent the relative intensity distributions.



Details of nozzle and skimmer

Fig. 6. Construction details for typical nozzle and skimmer.



22.20 A supersonic nozzle skims off some of the molecules of the jet and leads to a beam with well-defined velocity.

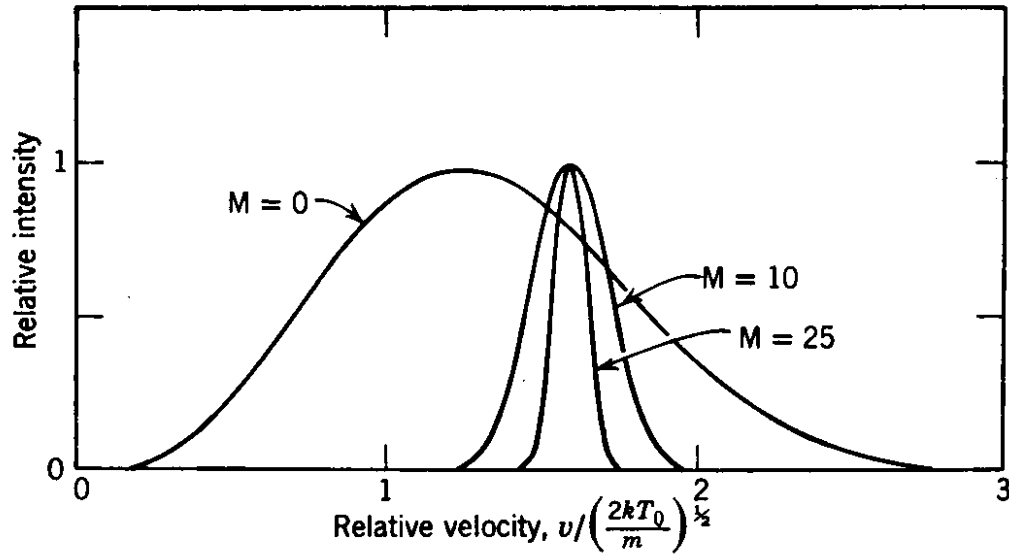

Fig. 2. Theoretical axial velocity distributions for nozzle source beams of monatomic gases with Mach number at the skimmer entrance as indicated. The distribution for an oven beam is also shown ($M = 0$).

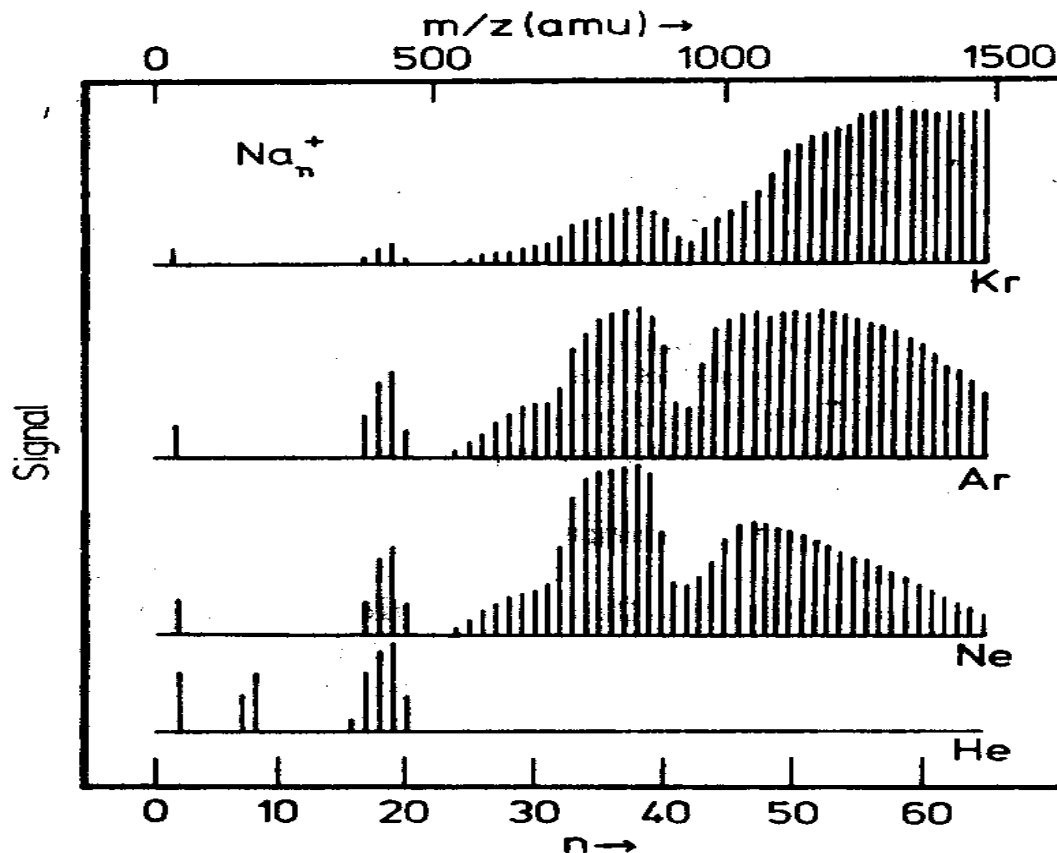

Figure 15.4 Photoionization mass spectra for sodium in inert gas-seeded beams. A 0.3-mm-aperture cylindrical nozzle was used throughout. The oven temperature was 800°C, corresponding to a sodium vapor pressure of 350 torr. Inert gas backing pressures were 1.3 atm in each case. Larger sodium cluster ions (Na_{65}^+) were detected for heavier carrier gases. Note that expansion of sodium vapor through the same nozzle without carrier gas results in comparatively small cluster abundances (the maximum cluster size observed was Na_{15}^+).

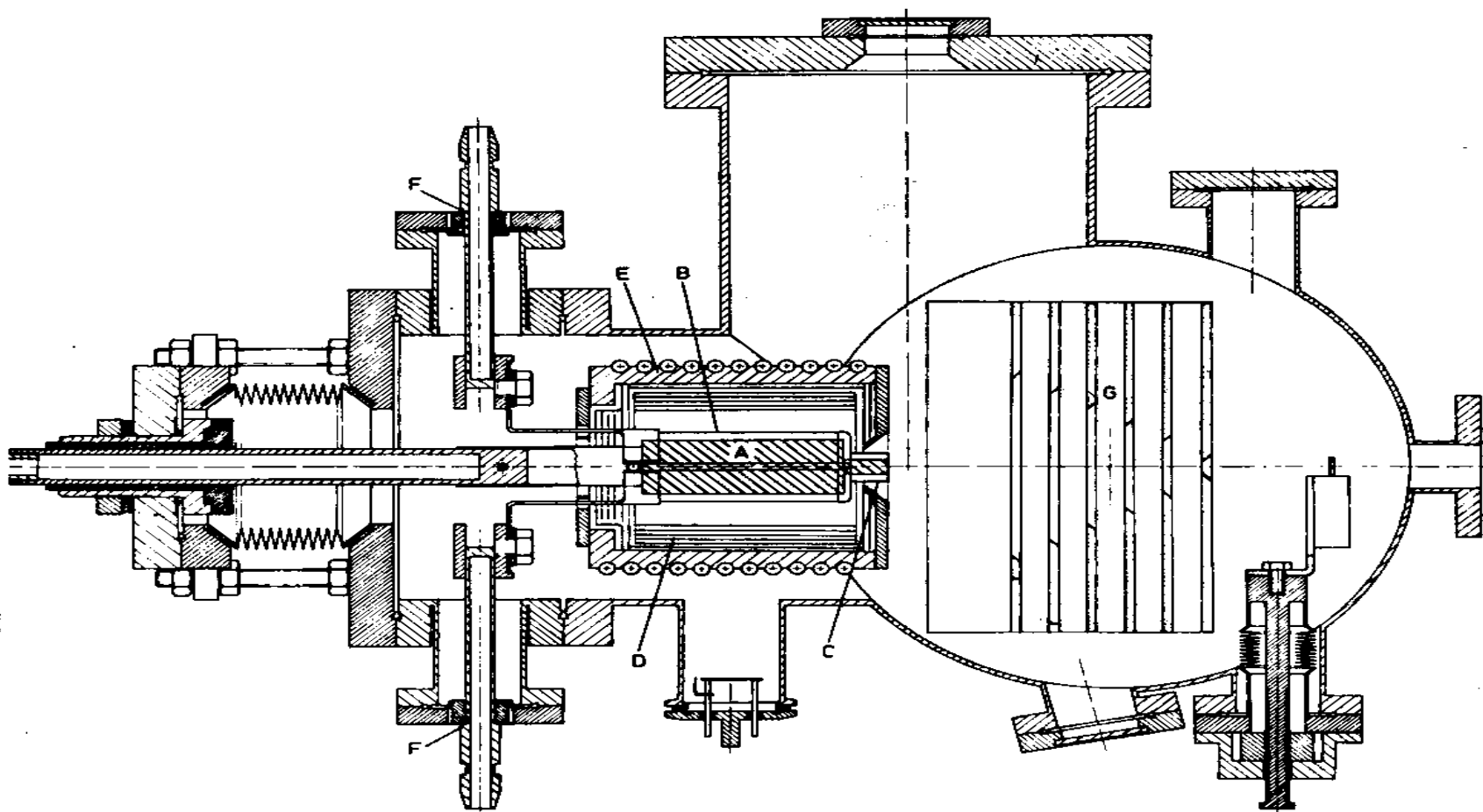

Figure 15.5 Horizontal cross section through a high-temperature oven used to generate continuous beams of lithium clusters: *A*, welded cartridge containing lithium sample; *B*, radiative graphite heater for cartridge body; *C*, tungsten wire nozzle heater (direct thermal contact); *D*, tantalum heat shields; *E*, water-cooled radiation shield; *F*, water-cooled current feedthroughs; *G*, liquid nitrogen-cooled beam collimator (Gerber 1980).

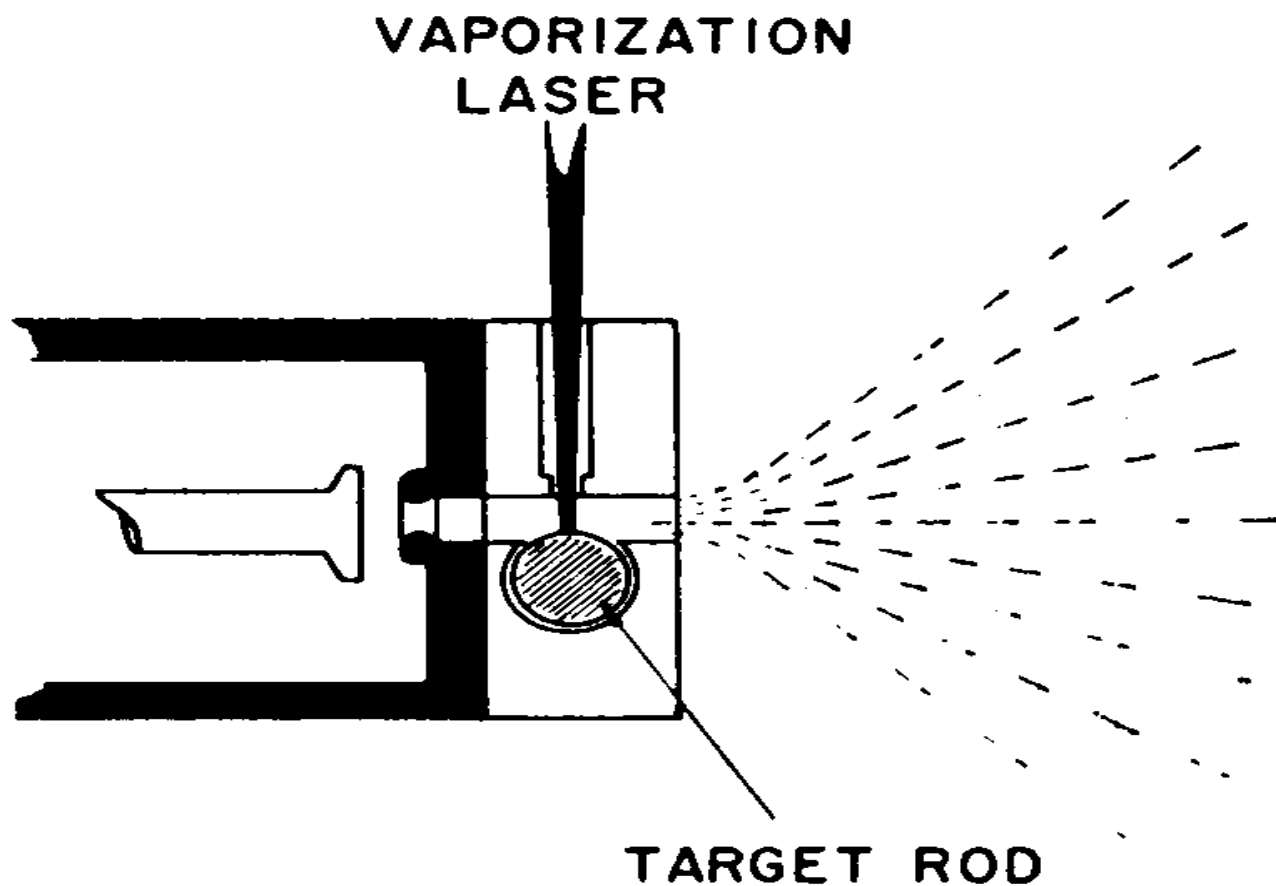

Figure 3.8 Schematic drawing of the pulsed metal cluster source developed by Powers et al. (1982).